

## SINGLE-ENDED CONNECTION

Up to 8 sensors can be connected directly to every channel.

### THREE-WIRE CONNECTION

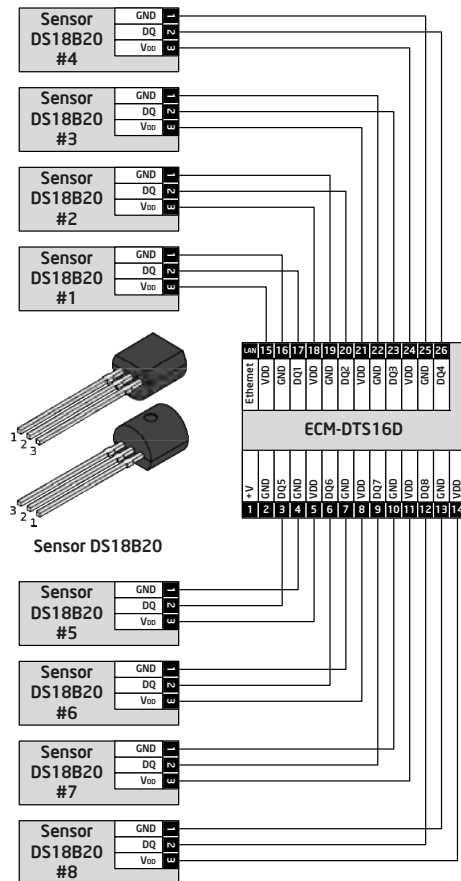

Three wires are used to connect sensors.

### TWO-WIRE CONNECTION

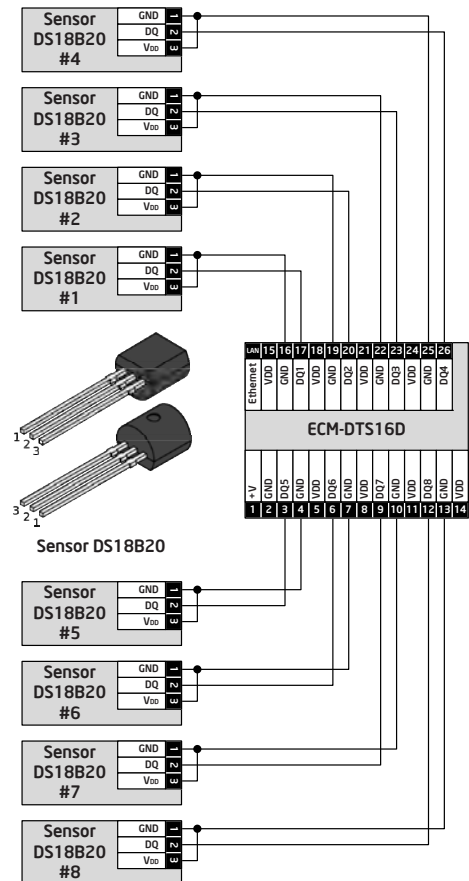

Two wires are used. The sensors derive power directly from the data line ("parasite power").

## BUS CONNECTION

Up to 16 sensors can be combined to a bus which is connected to terminals of the **group #1**.

### THREE-WIRE CONNECTION

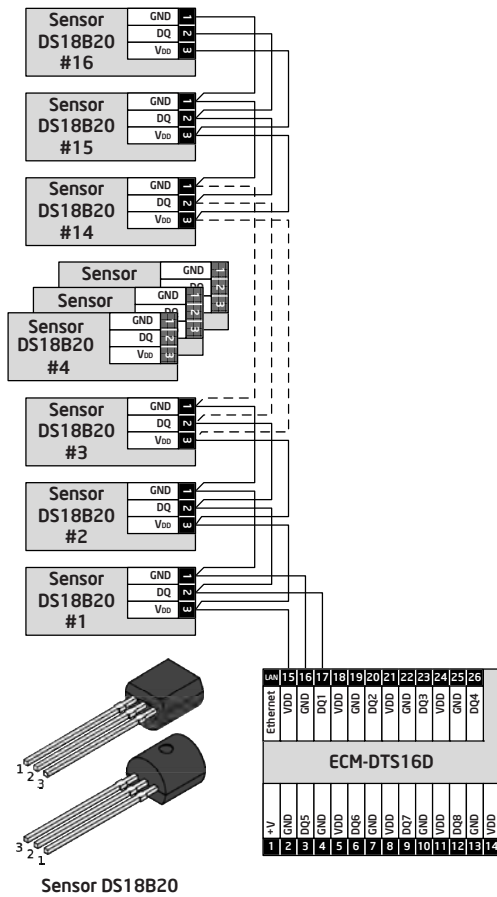

### TWO-WIRE CONNECTION

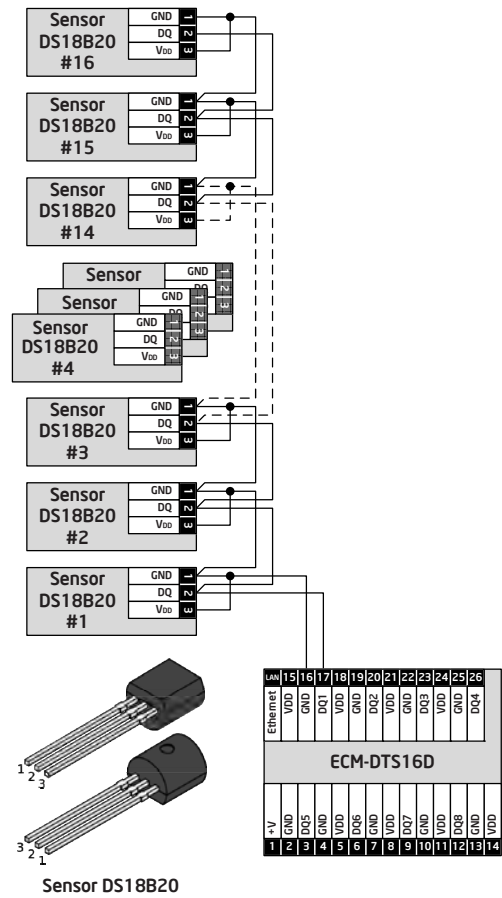

**Three wires** are used to connect sensors to the bus.

**Two wires** are used. The sensors derive power directly from the bus data line ("parasite power").

For further information refer to [www.highcross.com](http://www.highcross.com)